



A division of Terry Young Ltd, New Zealand

INSTALLATION INSTRUCTIONS for **XANDER INSERT** WOOD BURNER

- Clean Air Sub 1.0
- Non Clean Air (Rural)

BUILT-IN “ZC” INSTALLATIONS

29 NOVEMBER 2017

- ❖ These instructions cover installations of the Yunca Xander Insert, where the optional “Zero Clearance Kit” is being used - enabling installation into a suitably constructed enclosure as per AS/NZS 2918: 2001.
- ❖ For Masonry, please refer to the separate instruction book.

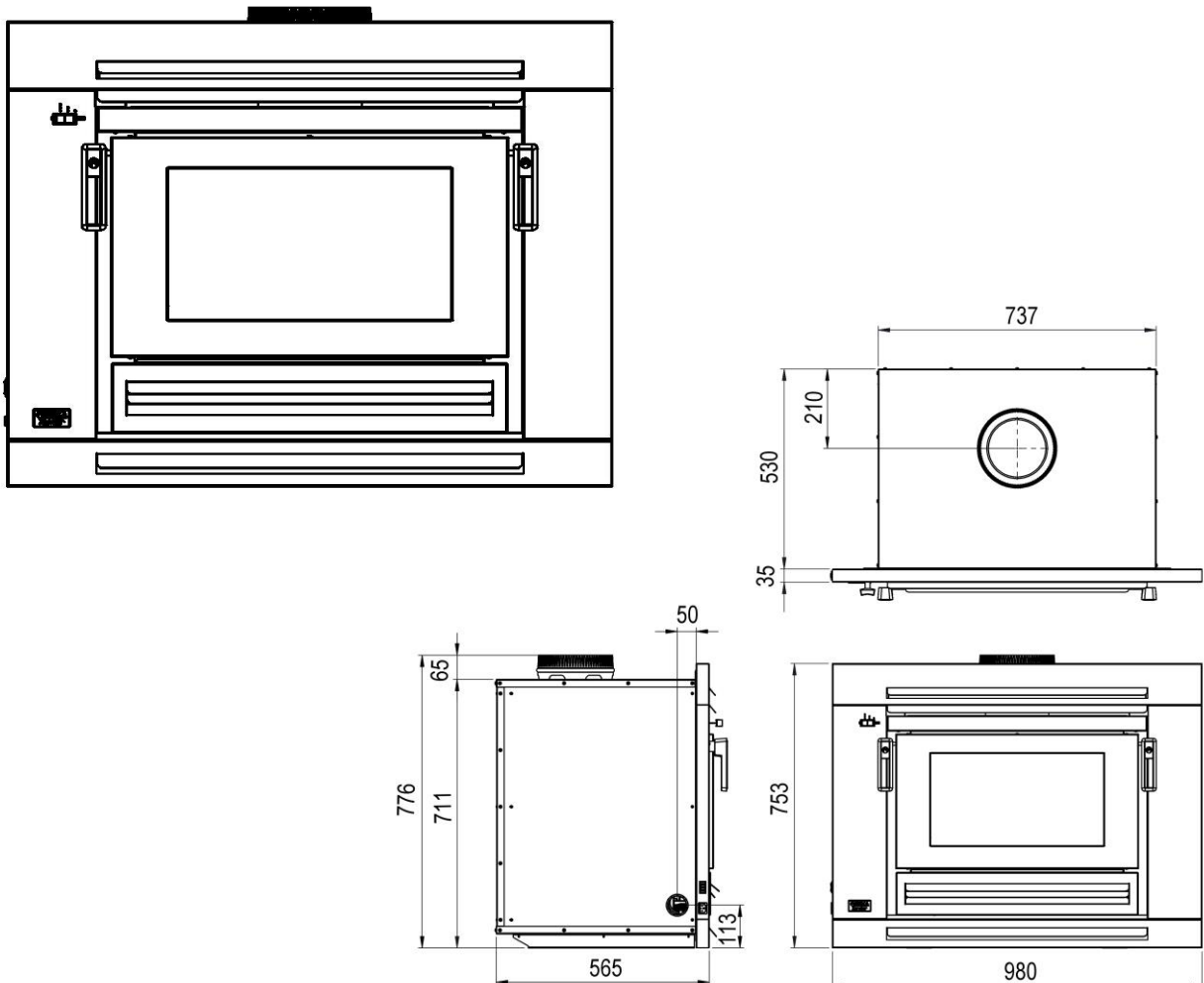

SAFETY INFORMATION

General:

- This appliance is not intended for use by persons (including children) with reduced physical, sensory or mental capabilities, or lack of experience and knowledge, unless they have been given supervision or instruction concerning use of the appliance by a person responsible for their safety.
- For the protection of young children, install an effective fire safety screen around your fire. Always keep children well away from the wood burner when it is alight.
- Supervise young children to ensure they do not play with the appliance.
- During initial burns of the appliance, ventilate the rooms well. It is recommended that babies, small children, pregnant women and pets should not be present in the area during initial burns as this is the firebox paint curing period.
- Do not make any modifications to the unit, and use it only in the manner described in the manual. Using it in any manner not recommended by the manufacturer may result in injury or death.

For units including electrical connections:

- If the wood burner is permanently connected to an electrical source, an isolating switch (wall switch) must be installed.
- New circuits or modifications, if required, but be made using the services of a certified electrician only.
- Ensure that the outlets you use are grounded properly, polarised and provided with fuse units.
- Ensure that the electrical plug is accessible after installation. The wood burner must not be located immediately below an electrical socket.
- Never operate the appliance with a damaged plug or cord, or if you observe the fan unit is malfunctioning or the heater has been damaged in any way. Call the authorised service person immediately for repairs or making electrical or mechanical adjustments. – Isolate the electrical supply in order to alleviate any potential risk.
- If the supply cord is damaged, the manufacturer, its service agent or a suitably qualified person must replace it in order to avoid electrical hazard. Any cord similar to the original can be used.

IMPORTANT INFORMATION

- I. It is imperative that you familiarise yourself with this entire document, and also ensure you have sufficient knowledge of relevant building regulations prior to proceeding with an installation.**
- II. The term “Zero Clearance”, or “ZC” is in common parlance, however it refers to reduced rather than actual nil clearances. Please refer to specifications in this document in conjunction with the relevant building code if unsure of clearances.**
- III. The appliance and flue system shall be installed in compliance with AS/NZS 2918:2001 and the appropriate requirements of the relevant building code or codes.**
- IV. Appliances installed in accordance with this standard shall comply with the requirements of AS/NZS 4013 where required by the regulatory authority i.e. the appliance shall be identifiable by a compliance plate with the marking “tested to AS/NZS 4013”**
- V. Any modification of the appliance that has not been approved in writing by the testing authority is considered to be in breach of the approval granted for compliance with AS/NZS 4013**
- VI. Mixing of appliance or flue system components from different sources or modifying the dimensional specification of components may result in hazardous conditions. Where such action is considered, the manufacturer should be consulted in the first instance.**
- VII. Cracked and broken components e.g. glass panels or fire bricks, may render the installation unsafe.**

TESTED in compliance with AS/NZS 2918: 2001

- A.** Yunca recommends that competent trades persons carry out all installations (e.g. NZHHA Registered Installer), to obtain maximum performance and safe, efficient heating.
- B.** A consent is required and we suggest you check with local building inspectors as by-laws do vary from area to area. Also notify your Insurance Company that a solid fuel heater has been installed.
- C. Floor Protector**
- C1.** Built-in (ZC) installations: Floor protector (Promina/Bellis Board or similar non-combustible material) must be installed so that its leading edge is a minimum of 500mm in front of the appliance base [with fascia attached]. **The floor protector must be a minimum of 860mm wide x 1090mm deep x 9mm thick.**
- C2.** Front floor protector clearances may be reduced if appliance is elevated. (Table 2)
- D. Seismic restraint.**
- D1.** Heater must be restrained from seismic movement (Fig. 9) as required by AS/NZS 2918:2001
- E. Heat sensitive materials exclusion zone.**
- E1.** Non-combustible front cladding **must be used**, to a minimum of 600mm above the top-most panel vent, and a minimum of 30mm either side of the fascia (152mm either side of the outer casing of the firebox (Zero Clearance Kit). (Fig. 5)
- E2.** No heat-sensitive material is permitted to contact the fascia forming or surrounding the front of the installation.
- E3.** No heat-sensitive material is to be placed any closer to the outer casing of the firebox than 600mm from the top, 20mm from either side, or 20mm from the rear.
- E4.** Where a nogging or lintel is required, a steel angle or other suitable non-combustible alternative should be used if within the aforementioned exclusion zone.
- F. Mantel Clearances.**
- F1.** Built-in Zero Clearance installation must have a minimum of 1300mm from the underside of the mantel shelf to the top of the appliance hearth. The mantel shelf must not protrude further than 250mm into the room. Minimum clearance of 1200mm from the underside of the mantel key (first combustible above appliance) to the top of the appliance hearth. The mantel key must not protrude further than 30mm into the room.
- F2.** All installations must have a minimum of 600mm vertically from the top vent to the nearest combustible material.
- F3.** **A 100mm heat deflector** must be installed directly above the fascia for the full width of the appliance if a mantel key or shelf is present.
- F4.** Mantel uprights must not protrude further than 70mm into the room, and be no closer than 30mm to the fascia on the side of the appliance where fans are (internally) hard wired. For units with external wiring using the included socket on the side panel, the side clearance to mantel uprights should be a minimum of 100mm to allow access to the electrical socket after installation.

G. Xander Wood Burner Dimensions

(Fig. 1)

- Dimensions given include the Built-in “Zero Clearance” cabinet and also the bottom infill fascia panel, which is required for ZC installations.
- Vented fascia top panel must be used for Built-in (ZC) installations.
(The blank fascia top panel is for masonry installations only)

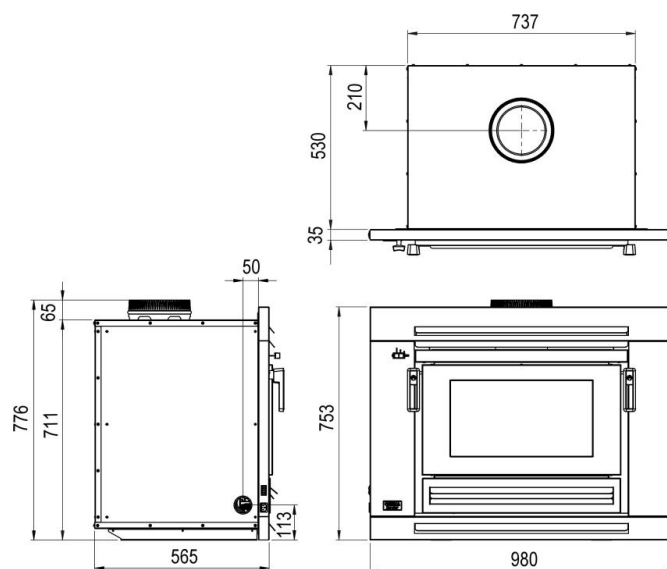

Fig. 1

H. Cavity Dimensions

H1. Cavity should be prepared based on the given minimum clearances or greater.

(Table 1) & (Fig. 2)

- Increasing the cavity dimensions slightly will make installation easier.
- Non-combustible material must be used on front wall between appliance and first nogging/frame of enclosure.
- Heat-sensitive structures not to contact carcass or appliance fascia.
- Ensure wiring for fan (Fig. 11) is taken into account when preparing cavity.

Table 1 BUILT-IN (ZC) CAVITY MINIMUM DIMENSIONS (mm)		
WIDTH (W)	HEIGHT (H)	DEPTH (D)
790	731	555

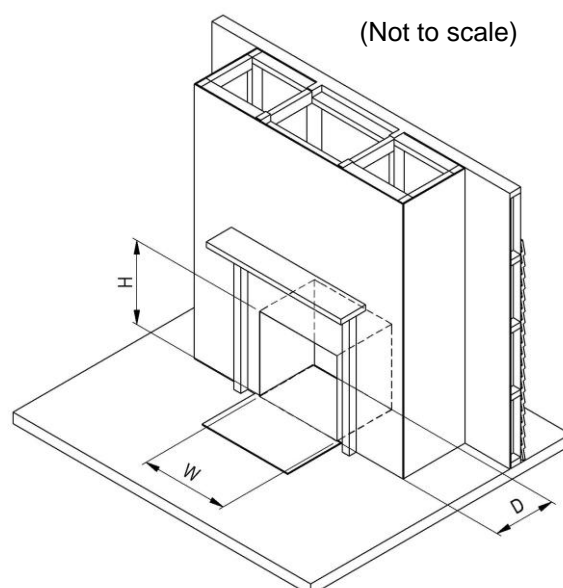

Fig. 2

WARNING:

Cavity Dimensions must be determined in conjunction with requirements as per Section E and Section L, with particular note made to the heat sensitive material exclusion zone.

WARNING:

A minimum of 450mm x 450mm space in the enclosure ceiling through which the flue system passes should be maintained to provide sufficient ventilation in order to prevent heat build-up within the enclosure.

WARNING:

The constructed enclosure should **not** be capped off at ceiling level, as there would be a considerable risk of fire from the build-up of heat. Such an installation should be properly vented into the ceiling cavity with sufficient clearances to comply with relevant building codes and practices.

WARNING:

For standard flue installations (Fig. 3); if any support is required under the chimney cap, it should be constructed of non-combustible materials only.

I. YUNCA Insert Flue Kit – Zero Clearance (Complies with AS/NZS 2918:2001):

11. Zero Clearance (Built-in) Flue Kit consists of the following:

- 4.8m x 150mm stainless steel flue.
- 4.8m x 200mm galvanised liner.
- 4.8m x 250mm galvanised liner.
- 1 x top cap & cowl (cone).

⇒ **Please Note:** All flue joints must be sealed with flue sealing compound. Use stainless steel screws or rivets to join the flue pipe (three equally spaced places at each joint). The first length of flue must be fixed to the flue spigot with at least one stainless steel screw or rivet. The required minimum flue termination height is 4.6 metres above the floor protector.

J. Typical Built-in (ZC) Flue Installation (Fig. 3)

Complies (with heater) to AS/NZS 2918:2001

(Not drawn to scale)

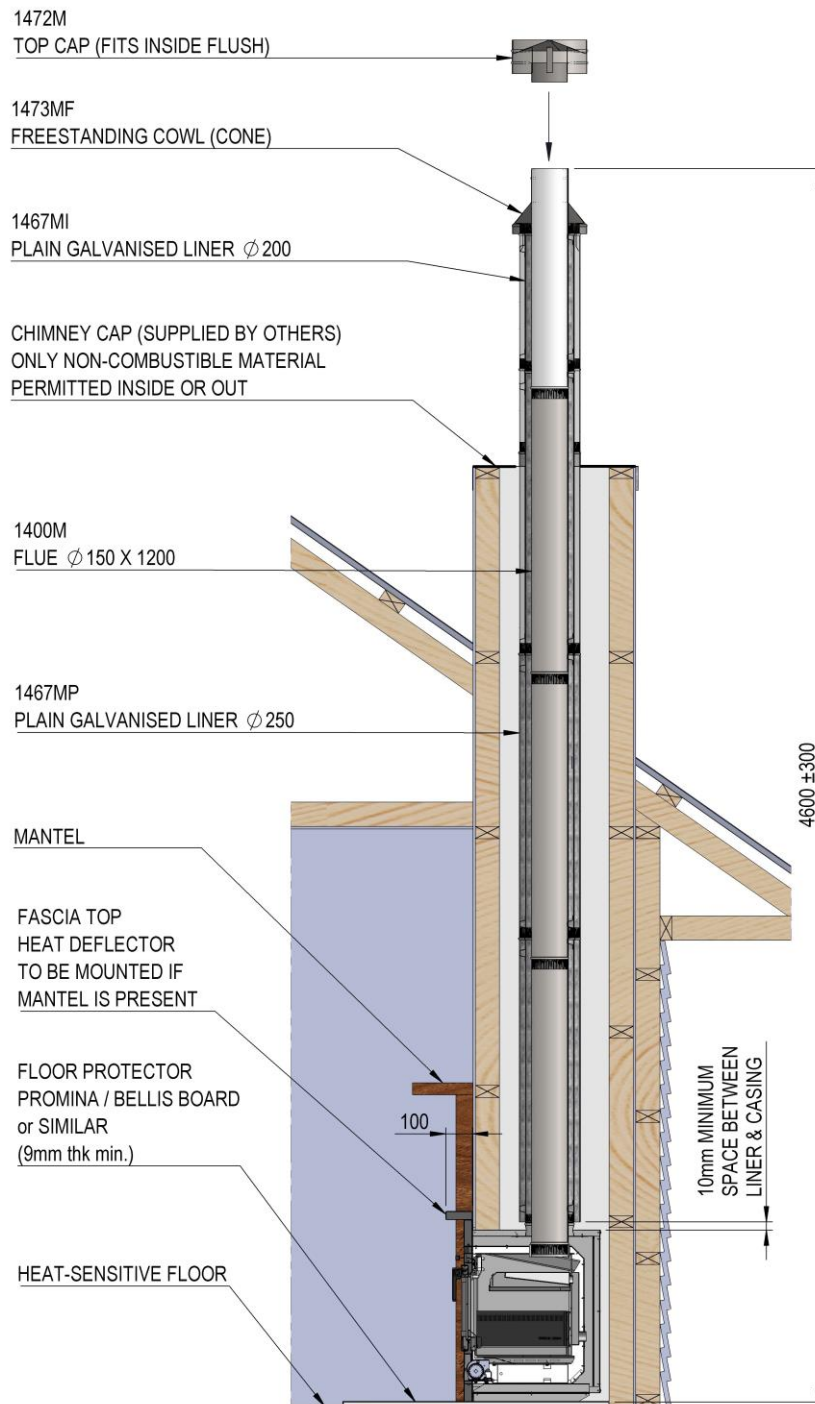

Fig. 3

K. Conditions for Flues (Fig. 4)

K1. The FLUE shall extend to:

- Not less than 600mm above the highest point on the roof if within 3.0m of that point, or
- Not less than 1000mm above the intersection point with the roof and not lower than any point of the roof within 3.0m.
- In any case the length of the flue shall not be less than 4.6m from the ash floor protector.

K2. In some situations the Local Council may vary the above requirements.

K3. The flue system must comply with AS/NZS2918:2001.

K4. A minimum of 25mm clearance must be left between the outer casing of the flue and any surrounding combustible materials.

K5. For situations where the cavity terminates at ceiling level, suitable measures must be taken to prevent accidental migration of loose-fill or any combustible material by any action of wind or by persons moving in the ceiling space. Such installations are not detailed in these instructions, so please refer to AS/NZS 2918:2001, and your local authorities for requirements.

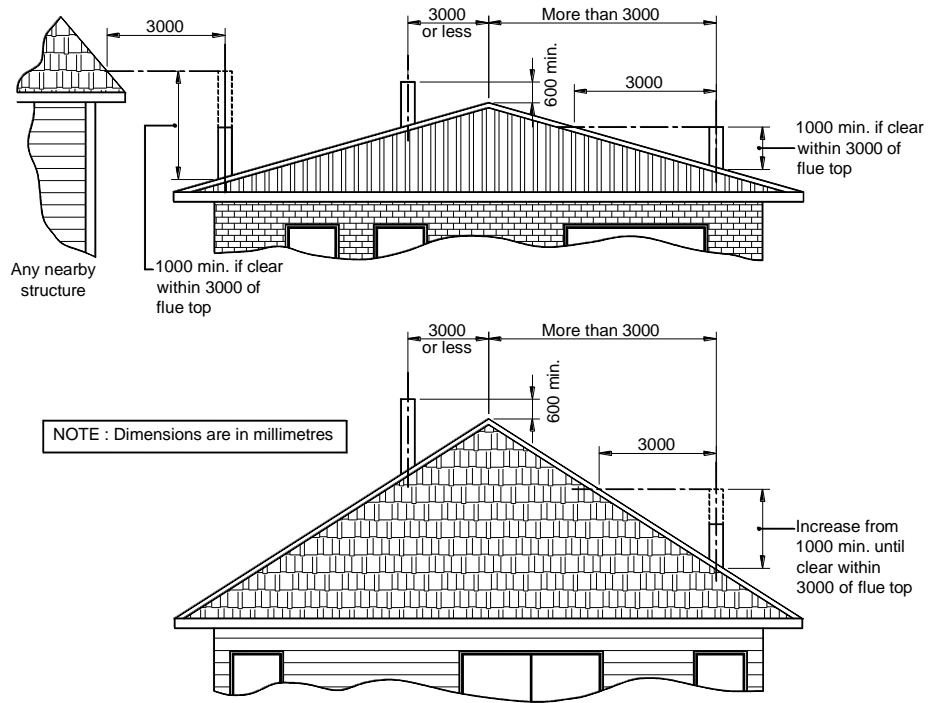

MINIMUM HEIGHT OF FLUE SYSTEM EXIT

Fig. 4

L. Xander Built-in (ZC) Installation Thermal Clearances

➤ THERMAL CLEARANCES FRONT VIEW

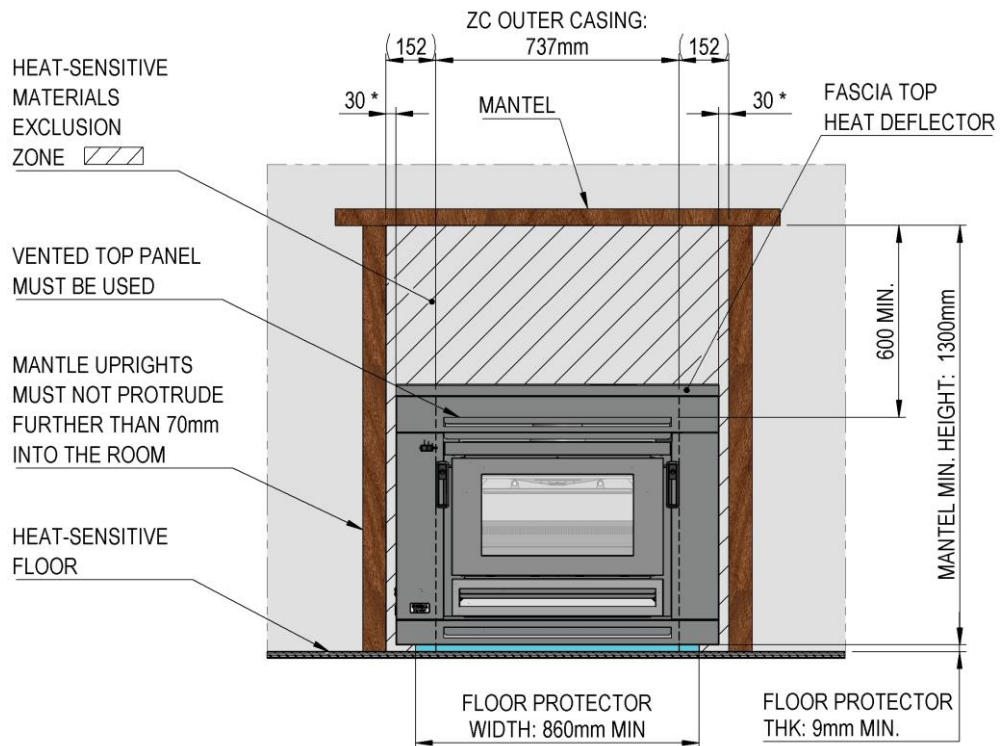

Fig. 5

➤ THERMAL CLEARANCES CROSS SECTION

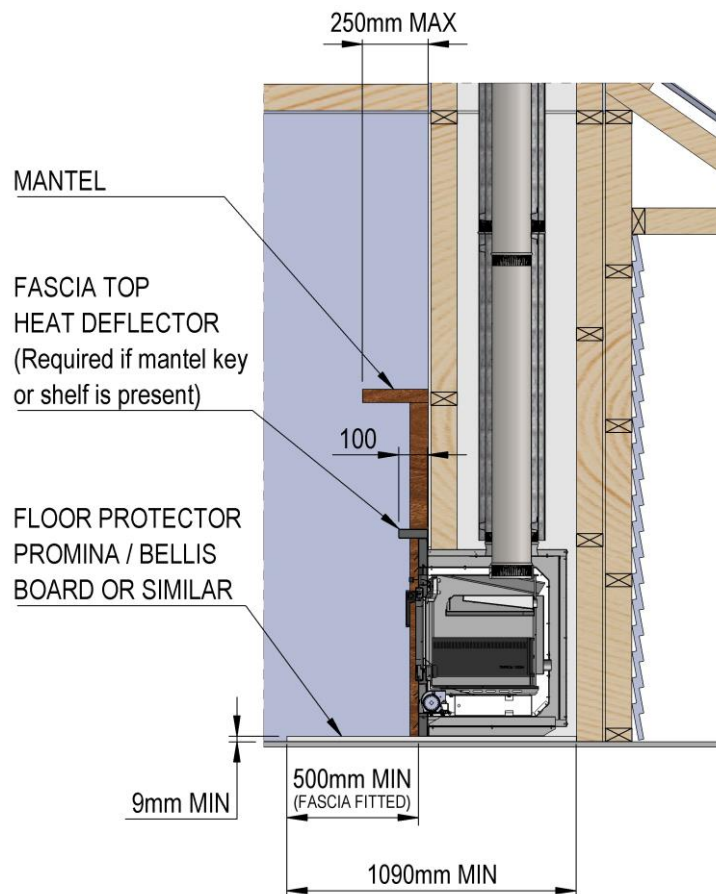

Fig. 6

M. Floor Protector Reductions

- M1.** The floor protector extension from the unit (Fig. 11) can be reduced if the unit is elevated. (Table 2)

Table 2. Floor Protector Reductions for Built-In Installations	Elevation Increase (mm)				
	0	50	100	150	200
Built-In (ZC)	500	464	421	366	300

N. Xander ZERO CLEARANCE KIT Assembly

- Note: The Xander “Zero Clearance Kit” (for built-in installations) is supplied as a flat pack and will require assembly before installation:

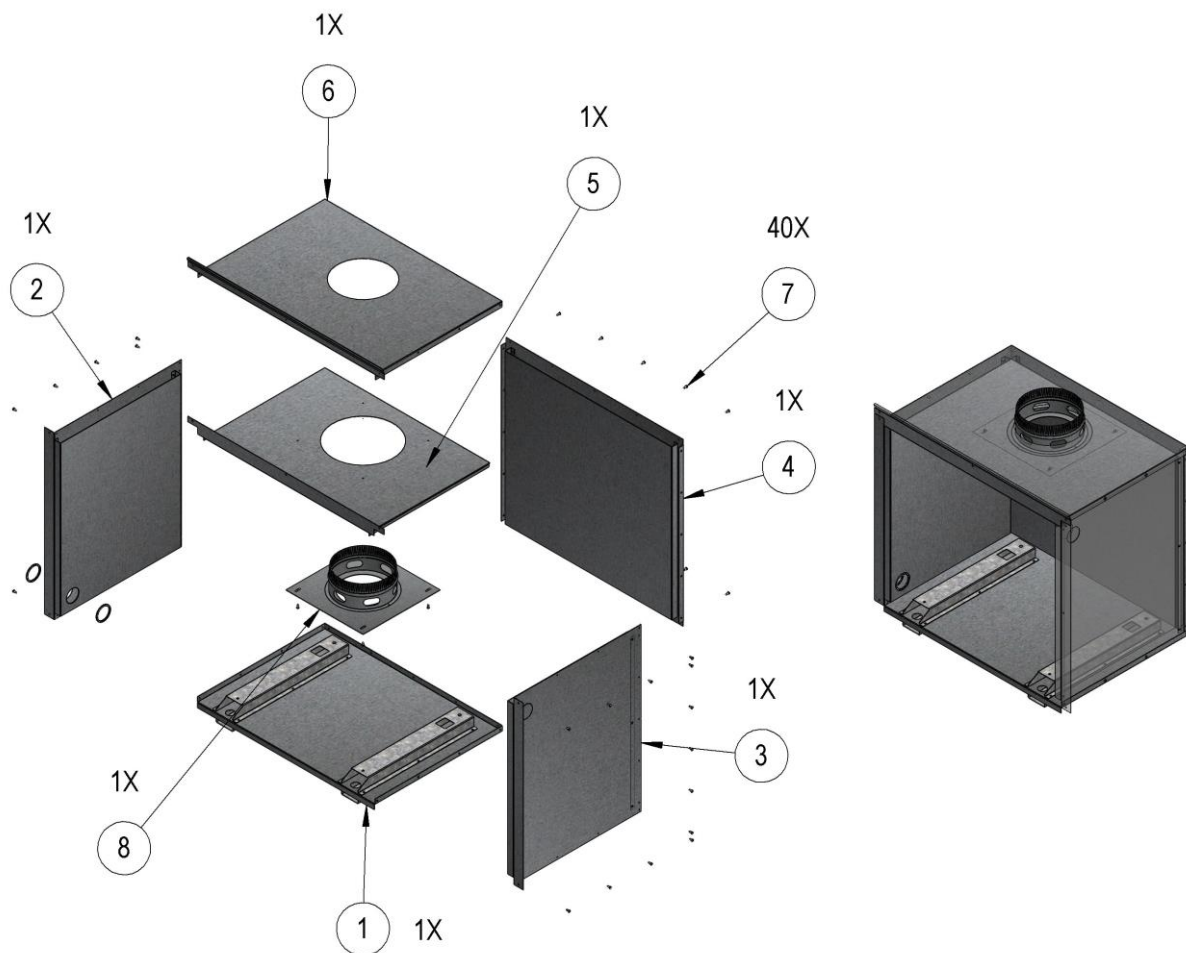

Fig. 7 – Zero Clearance Kit parts breakdown

ITEM	DESCRIPTION	QTY
1	CASING PANEL ASSEMBLY – BASE	1
2	CASING PANEL ASSEMBLY - LEFT SIDE (SIDE-HOLE OPEN WITH RUBBER GROMMETS)	1
3	CASING PANEL ASSEMBLY – RIGHT SIDE (SIDE HOLE COVERED)	1
4	CASING PANEL ASSEMBLY – BACK	1
5	CASING PANEL – TOP INNER	1
6	CASING PANEL – TOP OUTER	1
7	8G x 1/2 PAN POZI SELF TAPPER ZP (0013)	40
8	CASING SPIGOT ADAPTOR	1

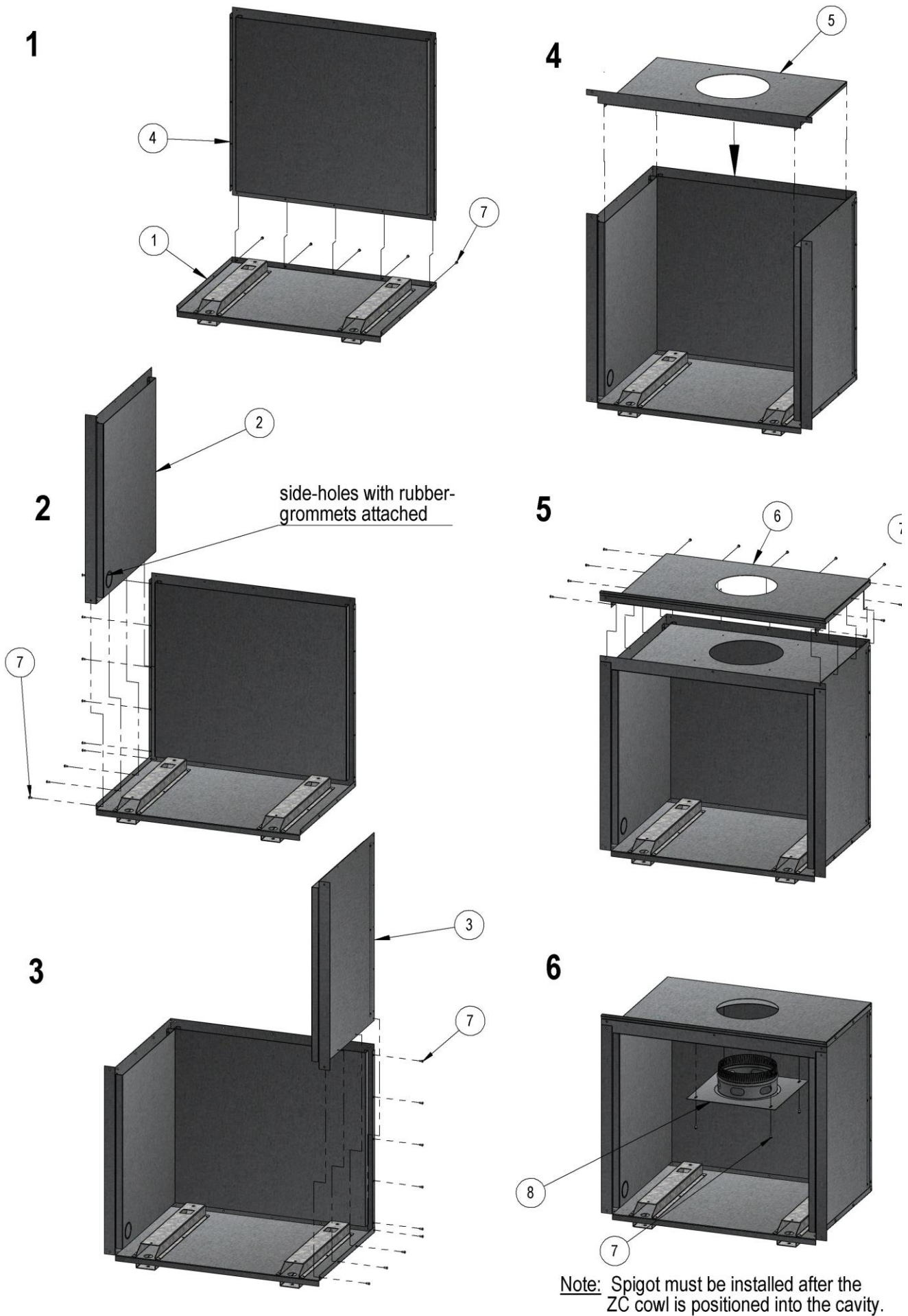

Fig. 8 - Zero Clearance Kit ASSEMBLY PROCEDURE

O. Xander Insert Seismic Fixings

01. Follow local Council's specifications.
02. Prior to installation, ensure the cavity floor is levelled. Also ensure the mantel face is perpendicular in relationship to the cavity floor.
03. Ensure the unit is securely fixed using sleeve anchors or similar at the locations shown in the images on this page. (Fig. 9)

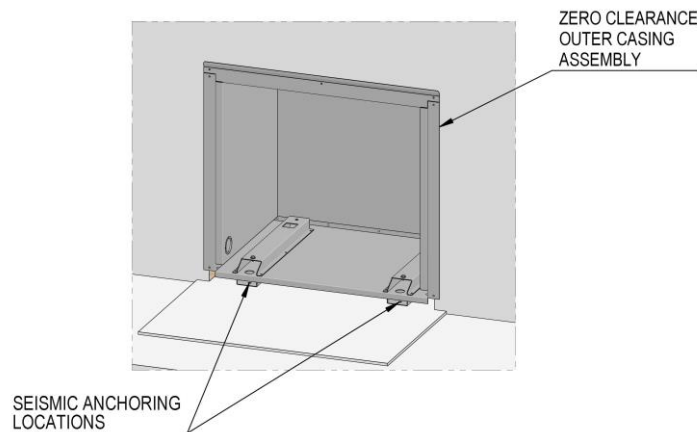

Fig. 9

P. Xander Flue Spigot Fixing (Fig. 10)

- Note: Access to affix the flue to the flue spigot is as follows:

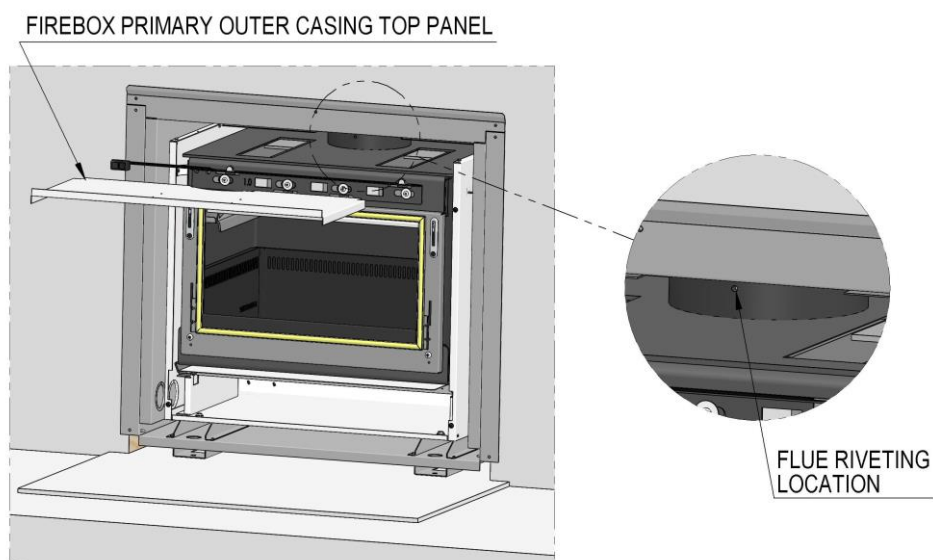

Fig. 10

- Note: Primary outer casing top panel must be installed after the flue is fixed in place.

Q. Fan Installation (Fig. 11)

- Q1. Take note of the entry and exit points for the cabling, and ensure measures are taken within the cavity to allow for this.
- Q2. Although the fan is controlled automatically by a thermostat it is recommended that an isolator switch is installed in conjunction.

⇒ WARNING

Ensure the fan is wired by a registered electrician, in compliance with all local regulations.

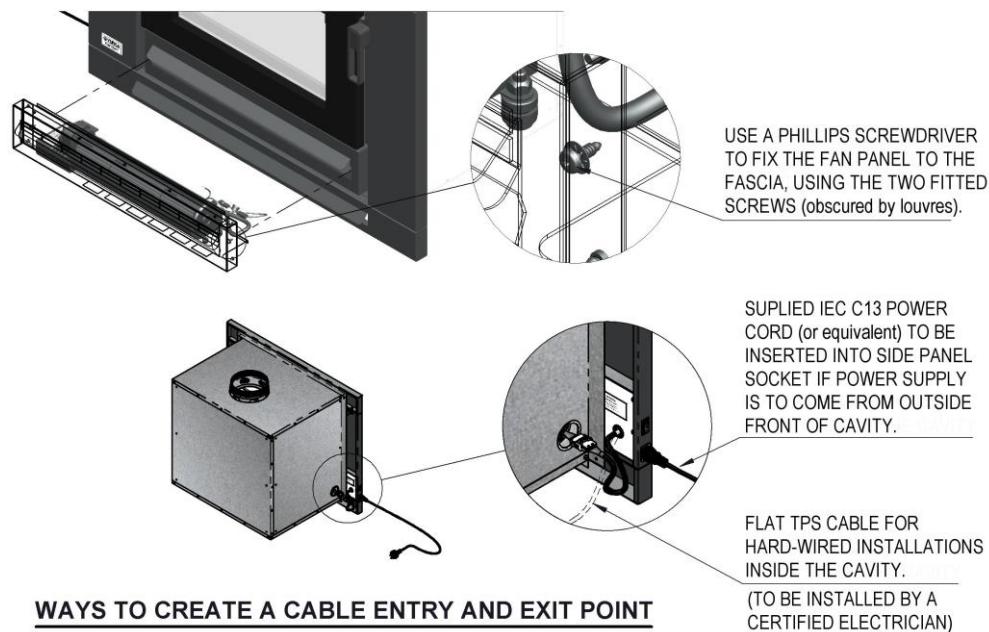

WAYS TO CREATE A CABLE ENTRY AND EXIT POINT

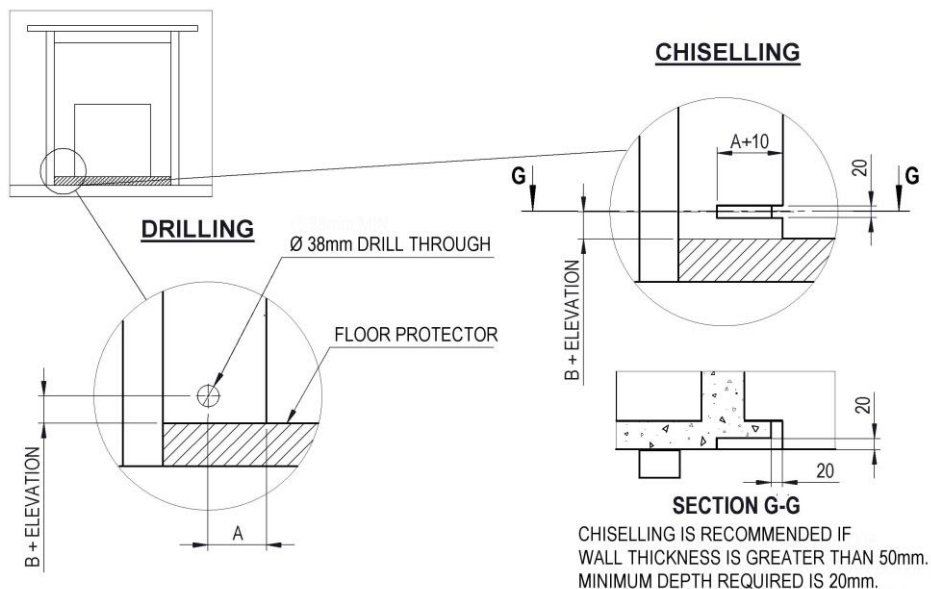

Fig. 11

INSTALLATION TYPE	FAN-SWITCH CABLE / POWER CORD ENTRY	
	A	B (TO BE ADDED TO ELEVATION)
ZERO CLEARANCE	47	123

R. Xander Wiring Connections

- R1.** Attach the two black thermostat leads to the thermostat terminals. (Fig. 12)
- Note: Thermostat is mounted to the underside of the heater in the fan cavity.
- R2.** Attach the thermostat Earth wire to the chassis of the heater. (Fig. 12)
- R3.** Join the 4-pole connector of the fan unit to the corresponding connector from the fascia. (Fig. 13) – Ensure they are securely locked.



Fig. 12

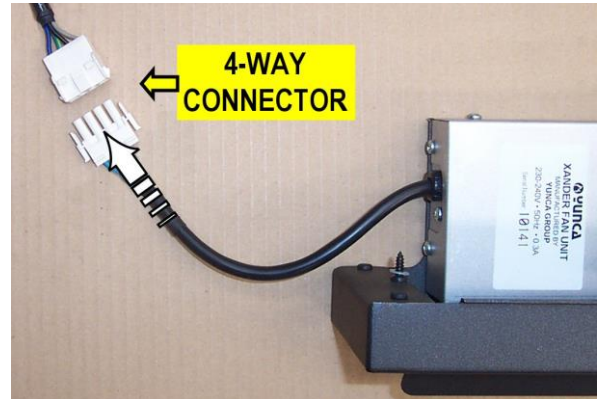

Fig. 13

- R4.** Mount the Fan unit and hearth to the fascia (Fig. 14) by securing the two screws as shown.
- ⇒ **WARNING**
When mounting the panel and fan assembly, any excess cabling (including the 4-pole connector) should be situated in the cavity outside of the firebox outer casing, and not in the high-temperature area under the firebox.
- R5.** Ensure all electrical connections are secure and suitably tested to applicable requirements.
- R6.** Connect the IEC C13 power plug to the IEC C14 socket (Fig. 15) in the side of the fascia.

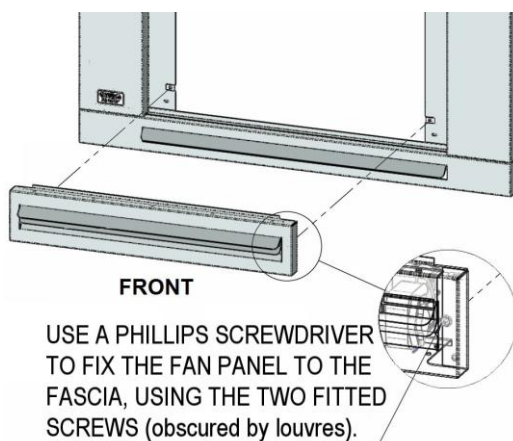

Fig. 14

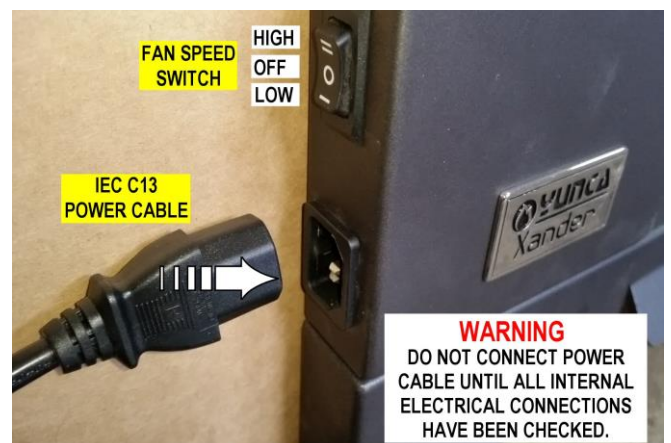

Fig. 15

- ⇒ **WARNING**
For hard-wired connections, the #0006238 cable must be disconnected and removed from the terminal block and IEC Socket. (Fig. 17)

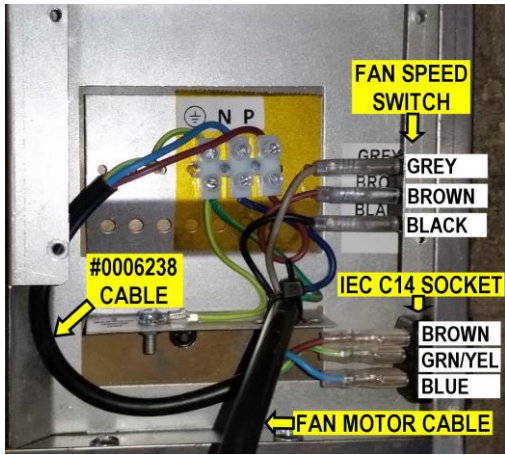

Fig. 16
Factory wired fascia circuit box

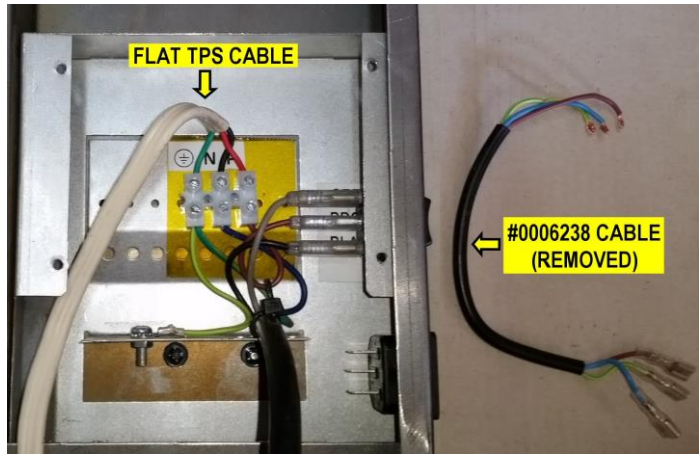

Fig. 17
Hard-wired fascia circuit box

< END >

These instructions, spare parts information, operation and maintenance guides may be downloaded from <http://www.yunca.co.nz/installation-operation/>